







PRISM Foundation downlight

(Foundation frame equipment)

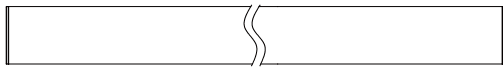

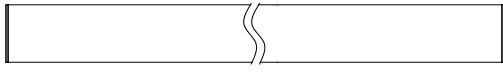

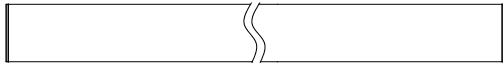









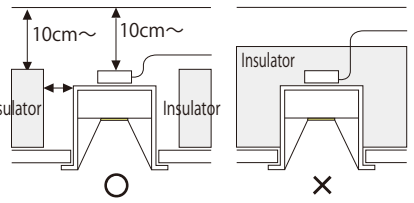









MPP-10/0300/F/R MPP-10/0300/F/J MPP-10/0300/F/L

MPP-10/0600/F/R MPP-10/0600/F/J MPP-10/0600/F/L

MPP-10/1200/F/R MPP-10/1200/F/J MPP-10/1200/F/L

			Weight
		 (For connecting right end)	MPP-10/0300/F/R MPP-10/0300/F/J MPP-10/0300/F/L 0.325kg
		 (For intermediate connection)	MPP-10/0600/F/R MPP-10/0600/F/J MPP-10/0600/F/L 0.650kg
		 (For connecting left end)	MPP-10/1200/F/R MPP-10/1200/F/J MPP-10/1200/F/L 1.300kg

To install the fixture safely 《 Read carefully and follow all the instructions in the guide 》

 Warning : Failure to install the fixture properly could result in personal injury.		 : Prohibited
 Caution : Failure to install the fixture properly could result in property damage.		: Strict observance
Before installation	 Warning	<p>The fixture is for indoor use only in general conditions. Can not be used following conditions (Causes of falling, electrocution and fire)</p> <ul style="list-style-type: none"> ●Inclined, uneven surface ●High humidity ●Outside ●On the floor ●Vibrated or shocked areas ●Areas get direct sunlight ●Insulated inside of ceiling ●Ceiling which can't hold the fixture weight ●On the wall ●Places affected by wind or air-conditioner machine ●Near fire ●Dusty areas, corrosive gas outbreaks areas ●Ambient temperature under 0°C and over 35°C <p>Please contact if you are not able to judge whether installation environment is suitable to the places or not.</p> 
	 Caution	 Please follow the fixtures' indication or specification for the distance of irradiated area. (Causes of change in shape, change in color of irradiated objects)
For electric wiring	 Warning	<p> Only qualified person may work on electric wiring and equipment. (Cause of accidents)</p> <p> Use alternating current. Please follow rating plate of fixtures for power supply frequency. (Cause of electrification · fire) (50Hz · 60 Hz common use for ballasts and incandescent lamp fixtures)</p> <p> Be sure power supply voltage is within ±6% mentioned in rating plate or the guide. (Causes of short life of lamps · electrification · fire)</p> <p> Be sure all the wires and codes are not damaged. (Causes of falling · damage)</p>
	 Warning	<p> Please follow the fixtures' instruction or this guide to install the fixture and lamp. (Causes of falling · electrification · fire)</p> <p> Switch off the power when installing the lamp. (Causes of electrification)</p> <p> Do not touch the fixture when switch is on or just turn off the switch because of high temperature.</p> <p> Do not put or cover the fixture by any cloths, papers, or insulators.(Causes of not lighting · fire)</p> <p> Do not place any metallic or flammable objects. (Cause of electrification · fire · broken fixture)</p> <p> Make sure to install all the parts of fixtures besides installation and mounting parts will not touch with any objects both inside and outside of ceiling such as lighting track, etc. (Causes of falling · electrification · fire)</p> <p> Do not dismount or remodel fixtures. (Cause of electrification · fire · falling · broken fixtures)</p> <p> Do not operate with wet hands.</p> <p> If you smell smoke, see smoke, or find anything unusual, please turn the switch off and ask construction companies to repair. (Cause of electrification · fire)</p>
	 Caution	 Make sure the construction will not affect any fire prevention systems such as sprinkler by heat from the fixture. (Causes for improper operation)

ModuleX

Installation Guide | Lighting Fixture

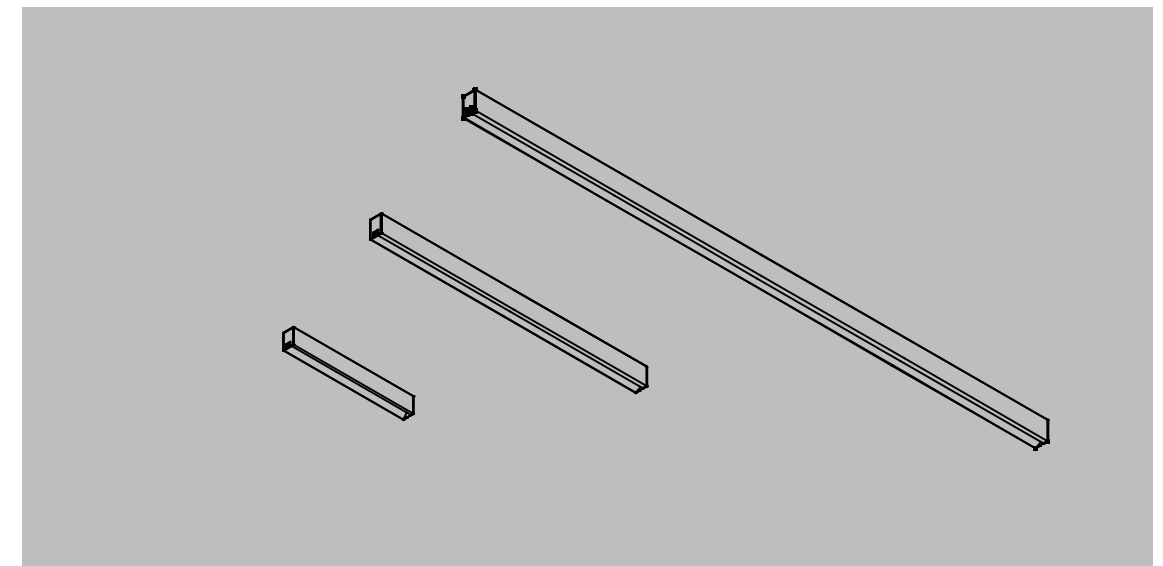

MPP-10/0300/F/R MPP-10/0300/F/J MPP-10/0300/F/L
 MPP-10/0600/F/R MPP-10/0600/F/J MPP-10/0600/F/L
 MPP-10/1200/F/R MPP-10/1200/F/J MPP-10/1200/F/L

Installation Details	Installation Diagram	Caution
<p>1 Power supply installation</p> <p>Connect the connecting cable with connector to the output of the driver.</p> <p>a When crimping, be sure to cut off the solder and crimp it. (Cause of poor crimp contact) Connect the connecting cable and driver according to the attached label.</p>		<p>a</p> <p>Electrical wire</p> <p>Cut off solder</p> <p>Please crimp in a place without solder</p> <p>Connect according to the polarity label attached to the connection cable.</p> <p>Polarity label for foundation</p> <p>Power connection DC cable (sold separately) MPP-OP/DC02/1000・3000</p>
<p>2</p> <p>Install the driver in the ceiling. (Make sure driver maintenance is possible in accordance with the technical standards for war equipment)</p>		
<p>Equipment installation (implantation, direct attachment)</p> <p>1 Open the safety wire mounting bracket downward and attach the safety wire.</p> <p>2 Connect the connector on the driver side and the connector on the instrument side.</p> <p>c Be sure to turn off the power before starting work.</p> <p>Check that the connector is locked and cannot be removed after connection.</p>		<p>c</p> <p>Input connector</p> <p>Output connector</p>
<p>3</p> <p>Bend inward so that the safety wire mounting bracket does not interfere with the instrument.</p> <p>The connector is placed between the mounting frame and the instrument, and the instrument is installed on the mounting frame.</p> <p>d Arrange the wires so that the connector does not tilt.</p> <p>Avoid mounting spring on the connector.</p> <p>Install without gaps between lighting fixtures.</p>		<p>d</p> <p>Connector is tilted</p> <p>Gap</p>
<p>4</p> <p>Install the instrument so that it is securely fixed to the frame mounting springs (2 places). Make sure that the instrument does not protrude from the frame.</p>		

Precautions	Contents																																																																																						
<p>Decide the number of units to be connected</p> <p>Decide the number of devices to be connected and the number of drivers according to the capacity of the driver.</p>	<p>Maximum output power of the driver (sold separately)</p> <table border="1"> <thead> <tr> <th>Model number</th> <th>Output power(W)</th> </tr> </thead> <tbody> <tr> <td>NTC-E060CV0241</td> <td>60</td> </tr> <tr> <td>NTC-E180CV0241</td> <td>180</td> </tr> </tbody> </table> <p>Total length of equipment that can be used by driver (excluding power consumption of the driver)</p> <table border="1"> <thead> <tr> <th colspan="2"></th> <th colspan="8">Driver model number: NTS-E060CV0241</th> </tr> <tr> <th>Full length</th> <th>mm</th> <th>300</th> <th>600</th> <th>900</th> <th>1200</th> <th>1500</th> <th>1800</th> <th>2100</th> <th>2400</th> </tr> </thead> <tbody> <tr> <td rowspan="2">Power consumption (W)</td> <td>Wall washer</td> <td>7.4</td> <td>14.8</td> <td>22.2</td> <td>29.6</td> <td>37.0</td> <td>44.4</td> <td>51.8</td> <td>59.2</td> </tr> <tr> <td>Foundation</td> <td>14.8</td> <td>29.6</td> <td>44.4</td> <td>59.2</td> <td></td> <td></td> <td></td> <td></td> </tr> </tbody> </table> <table border="1"> <thead> <tr> <th colspan="2"></th> <th colspan="7">Driver model number: NTS-E180CV0241</th> </tr> <tr> <th>Full length</th> <th>mm</th> <th>1500</th> <th>1800</th> <th>2100</th> <th>2400</th> <th>2700</th> <th>3000</th> <th>3300</th> <th>3600</th> <th>~7200</th> </tr> </thead> <tbody> <tr> <td rowspan="2">Power consumption (W)</td> <td>Wall washer</td> <td></td> <td></td> <td></td> <td></td> <td>66.6</td> <td>74.0</td> <td>81.4</td> <td>88.8</td> <td>~177.6</td> </tr> <tr> <td>Foundation</td> <td>74.0</td> <td>88.8</td> <td>103.6</td> <td>118.4</td> <td>133.2</td> <td>148.0</td> <td>162.8</td> <td>177.6</td> <td></td> </tr> </tbody> </table> <p>Note When connecting, instruments can be connected with connectors, but the total length of connections should be within 2.4m. Exceeding 2.4m may cause equipment failure. When connecting more than 2.4m, do not connect with the connector, and connect to the power driver in 2 circuits.</p> <p>When three L1200s are connected</p>	Model number	Output power(W)	NTC-E060CV0241	60	NTC-E180CV0241	180			Driver model number: NTS-E060CV0241								Full length	mm	300	600	900	1200	1500	1800	2100	2400	Power consumption (W)	Wall washer	7.4	14.8	22.2	29.6	37.0	44.4	51.8	59.2	Foundation	14.8	29.6	44.4	59.2							Driver model number: NTS-E180CV0241							Full length	mm	1500	1800	2100	2400	2700	3000	3300	3600	~7200	Power consumption (W)	Wall washer					66.6	74.0	81.4	88.8	~177.6	Foundation	74.0	88.8	103.6	118.4	133.2	148.0	162.8	177.6	
Model number	Output power(W)																																																																																						
NTC-E060CV0241	60																																																																																						
NTC-E180CV0241	180																																																																																						
		Driver model number: NTS-E060CV0241																																																																																					
Full length	mm	300	600	900	1200	1500	1800	2100	2400																																																																														
Power consumption (W)	Wall washer	7.4	14.8	22.2	29.6	37.0	44.4	51.8	59.2																																																																														
	Foundation	14.8	29.6	44.4	59.2																																																																																		
		Driver model number: NTS-E180CV0241																																																																																					
Full length	mm	1500	1800	2100	2400	2700	3000	3300	3600	~7200																																																																													
Power consumption (W)	Wall washer					66.6	74.0	81.4	88.8	~177.6																																																																													
	Foundation	74.0	88.8	103.6	118.4	133.2	148.0	162.8	177.6																																																																														
<p>Equipment that can be attached to the mounting frame and direct mounting plate</p> <p>300 types</p> <p>600 types</p> <p>1200 types</p> <p>Note: 300 instruments cannot be installed on 1200 mounting frames</p>																																																																																							