

Specification

- Frame Inside black
- Weight 3.0Kg

Product Code
SX-LF083

Fixture (Sold Separately)
SL-505/80DFC/CE
SL-535/80DFC/CE

Ceiling Cut Out
217 × 432

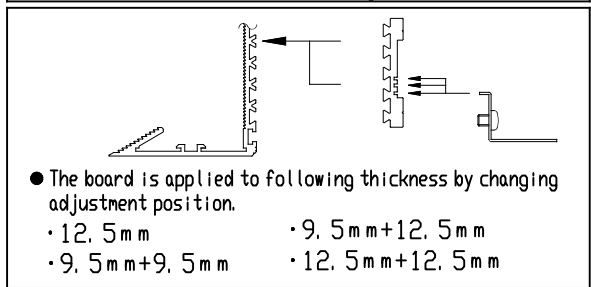
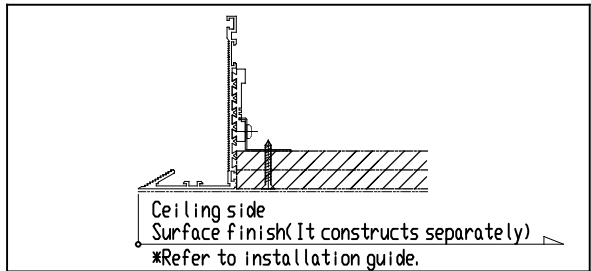
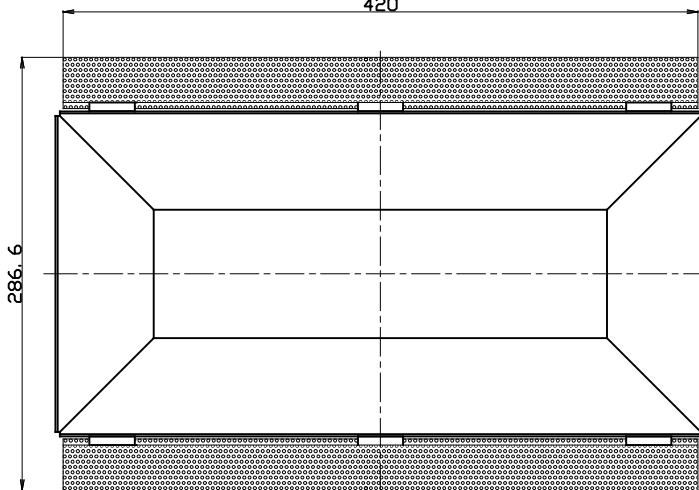
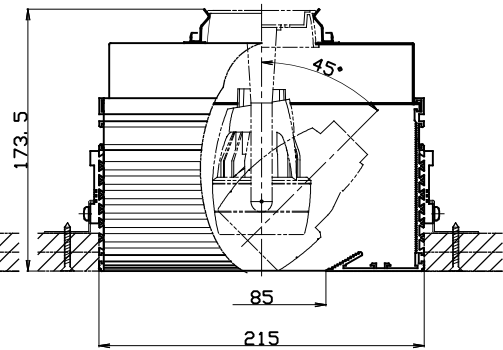
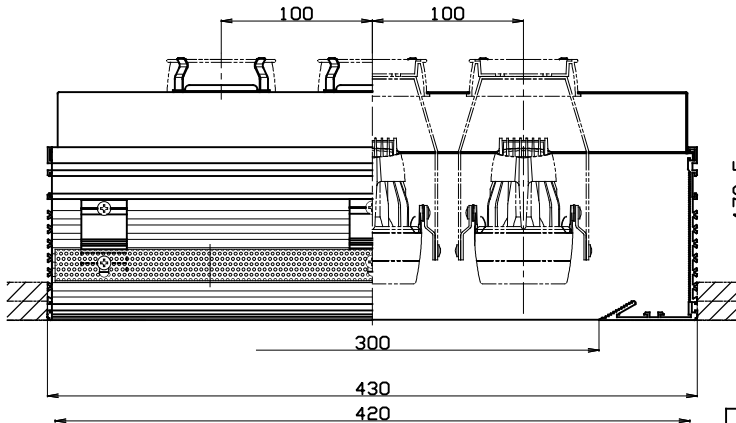

PARTS	MATERIAL	REMARK
1 Spring	Stainless	
2 Box	Steel plate	
3 Fixtures		Sold Separately
4 Main Unit	Aluminum Extrusion	Anodic coating
5 Attachment	Aluminum Extrusion	Anodic coating
6 Bracket	Aluminum Punching	
7 Drilling tapped screw	Iron	Plating

Attention

- Danger: Do not remodel fixtures.
- Do not cover the fixtures and ballast with the heat insulator etc.
- Refer to the installation guide for the construction method.
- Use lawn for construction. If not, it will cause some crack.
- Make sure to use provided number of drilling tapped screws.
- Install the drilling tapped screws as close as to the edge of box.
- Be accurate in dimensions of ceiling cut out.
- To install an inverter safely, please make sure your ceiling has at least 270mm or more clearance inside.

