

SERIES

FUNCTION

CAT, No

ModuleX

Linear100

SX-LB102S/900

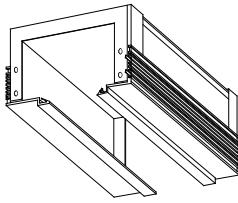

SPECIFICATION

- Frame Inside black
- Weight 7.1kg

PRODUCT CODE

SX-LB102S/900

FIXTURE (SOLD SEPARATELY)

- SX-505LE/CE
- SX-505LEC/CE
- SX-535LE/CE
- SX-535LEC/CE
- SX-900LE/CE
- SX-910LE/CE

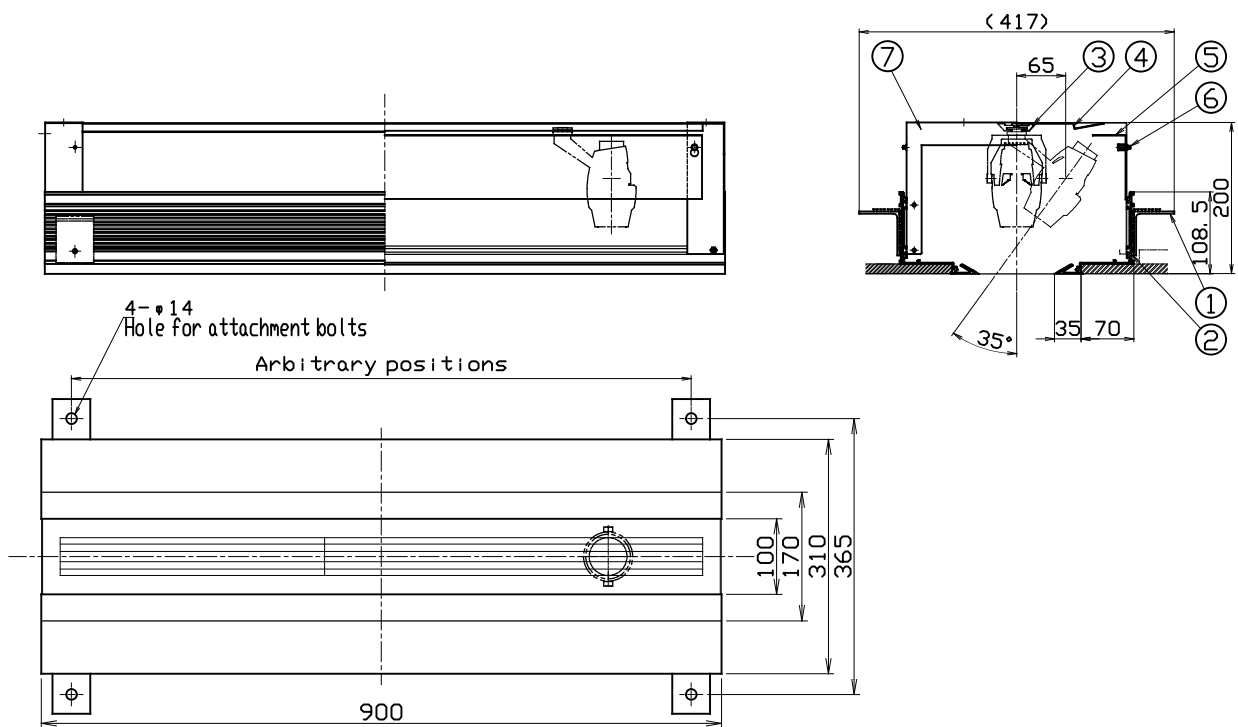

	PARTS	MATERIAL	REMARK
1	Bracket	Aluminum Extrusion	
2	Body Frame	Aluminum Extrusion	Anodic coating
3	Slide Rail	Aluminum Extrusion	Black Anodic coating
4	Plate	Zinc Plate	Black
5	Cover for Maintenance	Zinc Plate	Black
6	Knurled screw	Brass	Black Finish
7	Connecton Frame	Zinc Plate	Black

Attention

- There is a risk that it may be injured at the end of a product. Be careful enough of handling.
- Please install correctly. Unstable installation has the danger of fall.
- Please refer to installation guide on how to install.
- Please do not cover with thermal insulation. There is a risk of generating heat and damaging fixture.
- Do NOT dismantle or remodel. Once it is dismantled, it cannot restore with original size.

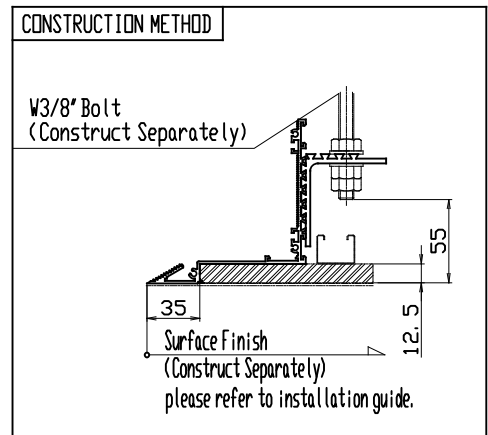

ModuleX
ModuleX Inc.

SPECIFICATION SHEET

SCALE
1/10

CREATED DATE
13/11/2015

REVISION DATE