

SERIES

FUNCTION

CAT, No

Linear100

Linear100

SX-LB101S/300

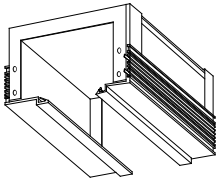

SPECIFICATION

- Frame Inside black
- Weight 2.7kg

PRODUCT CODE
SX-LB101S/300

FIXTURE (SOLD SEPARATELY)
SX-505LE/CE
SX-535LE/CE

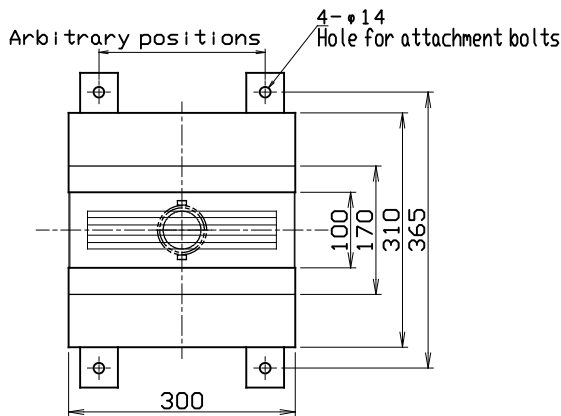
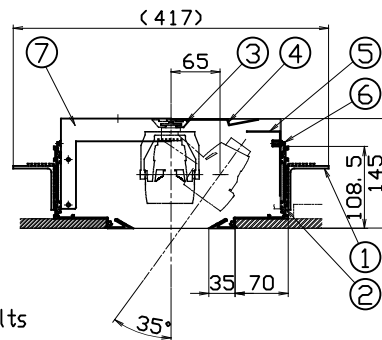
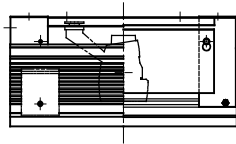

PARTS	MATERIAL	REMARK
1 Bracket	Aluminum Extrusion	
2 Body Frame	Aluminum Extrusion	Anodic coating
3 Slide Rail	Aluminum Extrusion	Black Anodic coating
4 Body	Zinc Plate	Black
5 Cover for Maintenance	Zinc Plate	Black
6 Knurled screw	Brass	Black Finish
7 Connection Frame	Zinc Plate	Black

Attention

- There is a risk that it may be injured at the end of a product. Be careful enough of handling.
- Please install correctly. Unstable installation has the danger of fall.
- Please refer to installation guide on how to install.
- Please do not cover with thermal insulation. There is a risk of generating heat and damaging fixture.
- Do NOT dismantle or remodel. Once it is dismantled, it cannot restore with original size.

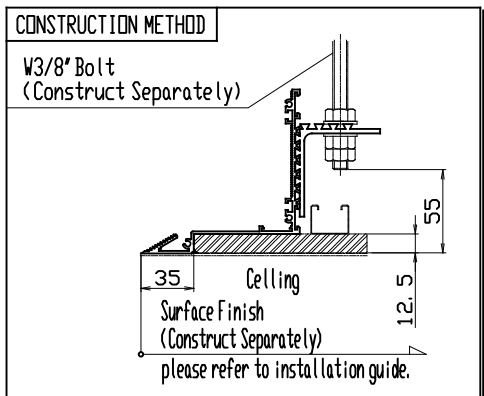

ModuleX
ModuleX Inc.

SPECIFICATION SHEET

SCALE
1/10

CREATED DATE
13/11/2015

REVISION DATE