

SPECIFICATION

- Light Source LED Module (Mounted)
- Body White(W) . Matte black(M) . Silver(S)
- Light Distribution Narrow(N) . Medium(M)
- Vertical aiming angle Upper10° . Lower90°
- Horizontal aiming angle 380°
- Input Voltage 220V±6%(Dedicated driver input voltage)
- Input current 0.101A(Dedicated driver input voltage, 220V input)
- Power Consumption 21.4W(Included dedicated driver, 220V input)
- Dedicated Driver Constant current (50/60Hz shared)
- Weight 625g
- tool for pan/tilt lock is equipped
- Dimming Control 0-10V
- Dimming Range 3%-100%

PRODUCT CODE

- MMP-080S/SH/W·M·S/1E/N/10B27/Z2/3
- MMP-080S/SH/W·M·S/1E/N/10B30/Z2/3
- MMP-080S/SH/W·M·S/1E/N/10B35/Z2/3
- MMP-080S/SH/W·M·S/1E/N/10B40/Z2/3
- MMP-080S/SH/W·M·S/1E/M/10B27/Z2/3
- MMP-080S/SH/W·M·S/1E/M/10B30/Z2/3
- MMP-080S/SH/W·M·S/1E/M/10B35/Z2/3
- MMP-080S/SH/W·M·S/1E/M/10B40/Z2/3

OPTION

- Full Diffuser Lens MLA-080/DF01
- Semi Diffuser Lens MLA-080/DS03
- Full Spread Lens MLA-080/SF01
- Semi Spread Lens MLA-080/SS01
- Edge Control Lens MLA-080/EC02
- Sharpener Lens MLA-080/SH01
(available only for narrow distribution)

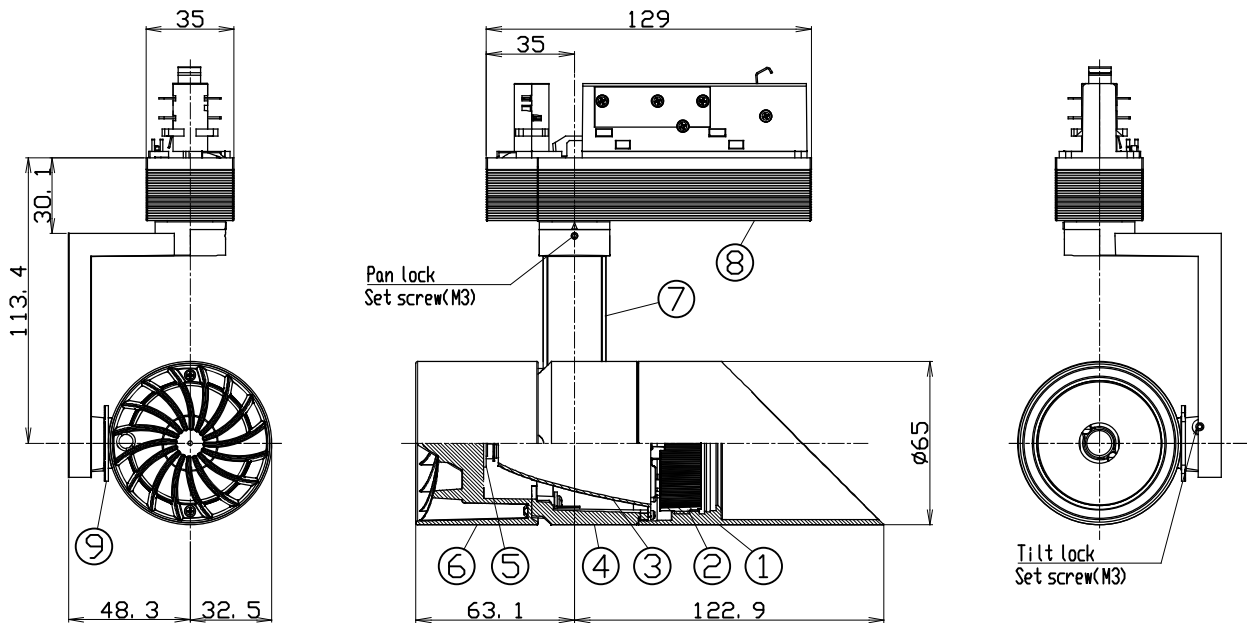

	PARTS	MATERIAL	REMARK
1	Hood	ADC	Acrylic Baking Finish
2	Option Holder	ADC	Acrylic Baking Finish
3	Reflector	Aluminum	
4	Body	ADC	Acrylic Baking Finish
5	LED Module		
6	Socket Holder	ADC	Acrylic Baking Finish
7	Arm	ADC	Acrylic Baking Finish
8	Dedicated Driver		0-10V control dimming system
9	Tilt Protractor	Resin	

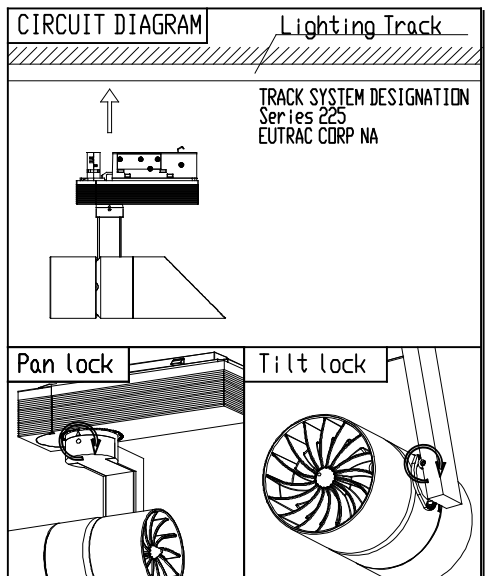

ATTENTION

- Emission color and brightness would be different even within the same model.
- Do not use a radio or TV near the fixtures. The unit may generate noise in the radio or TV.
- Danger! Do not remodel fixtures.
- Please do not install to the wall or floor
- Use within 0℃~35℃ ambient temperature range
- Use 0-10V control dimming system (DVSTV-XX(Sold separately)) only.
- Keep distance of the fixtures and objects 0.2m or more.
- To remove heat, place an air hole when installing the fixture in a fitting.
(Place air holes equally in the upper side of the fitting. Total aperture size should be more than 5% of the fitting's surface)
- Please do not move the fixture body under the situation the pan/tilt lock works.
- Please do not unfasten the set crew for pan/tilt lock too much. Otherwise, it may be dropped and lost.
- This fixture can be attached to the 3 circuit rails, but only 1circuit can be used for power supply.
- Please do not attach the fixture to the 3 circuit rails in which more than 1 circuit are occupied for power supply. It may cause tripping the circuit breaker.